

REVISIONS				
ZONE	REV	DESCRIPTION	DATE	APPROVED

FRONT VIEW

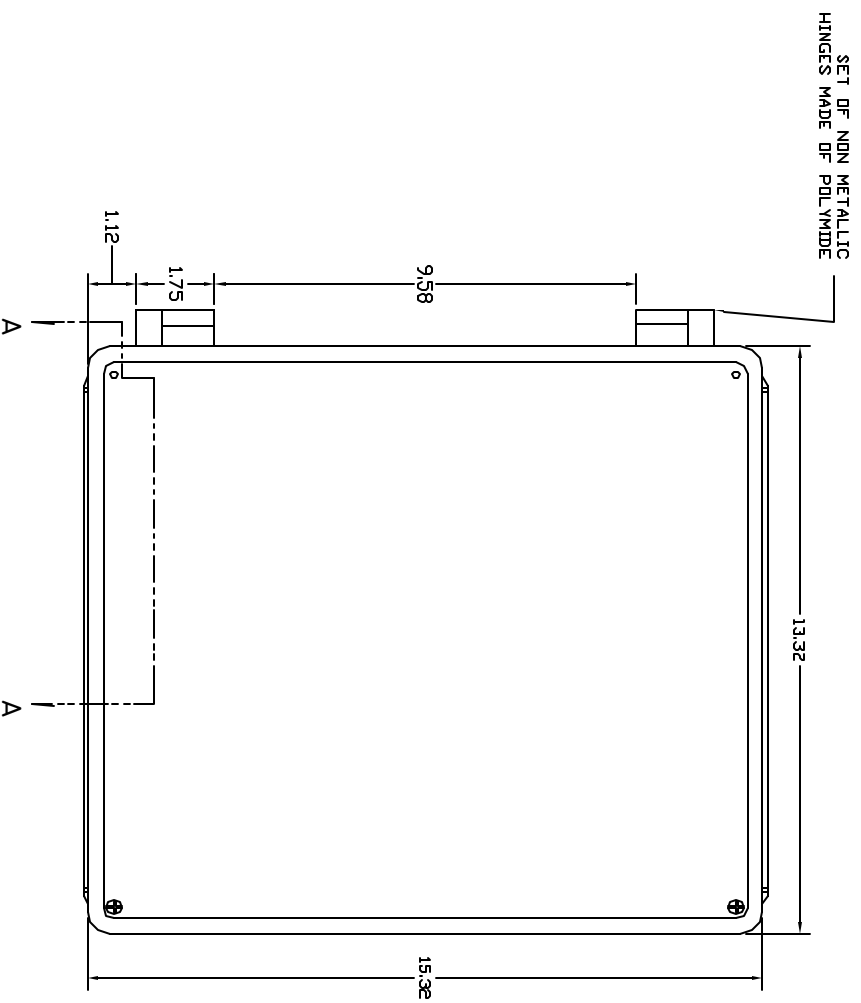

RIGHT SIDE VIEW

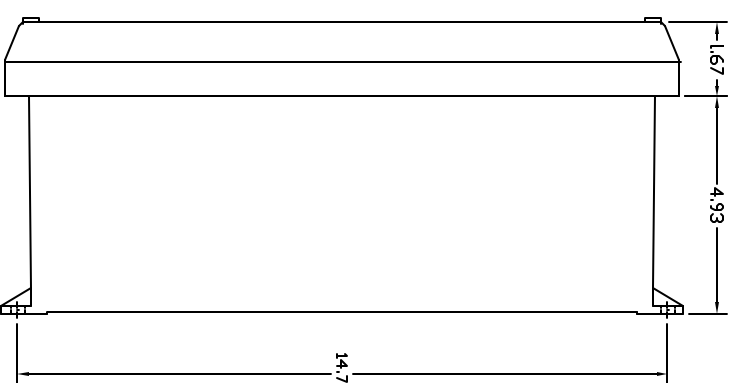

FRONT VIEW—COVER REMOVED

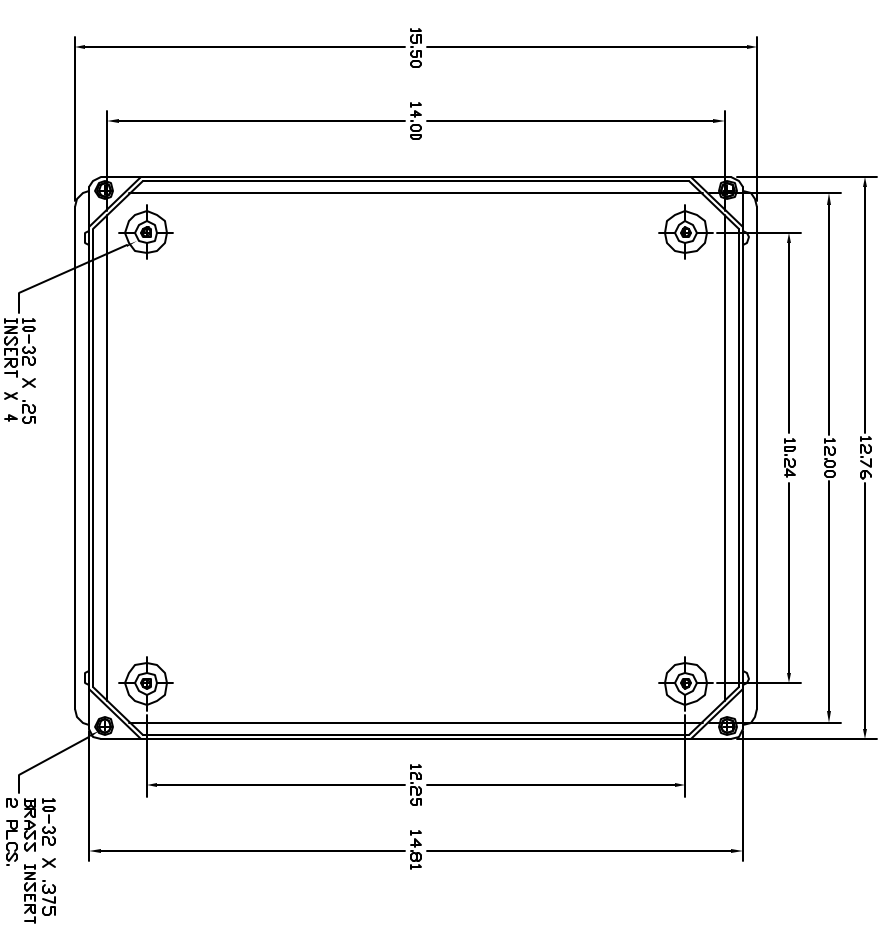

END VIEW

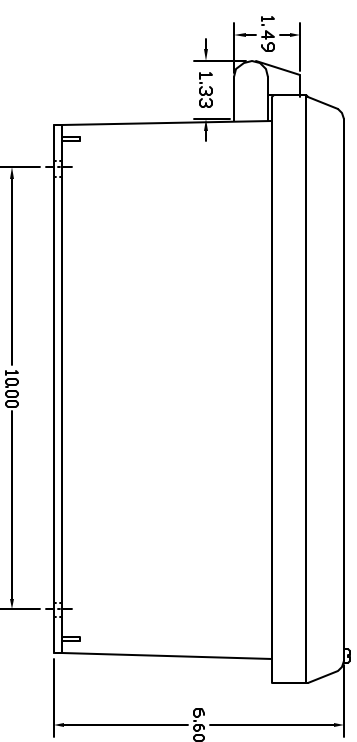

SECTION A-A

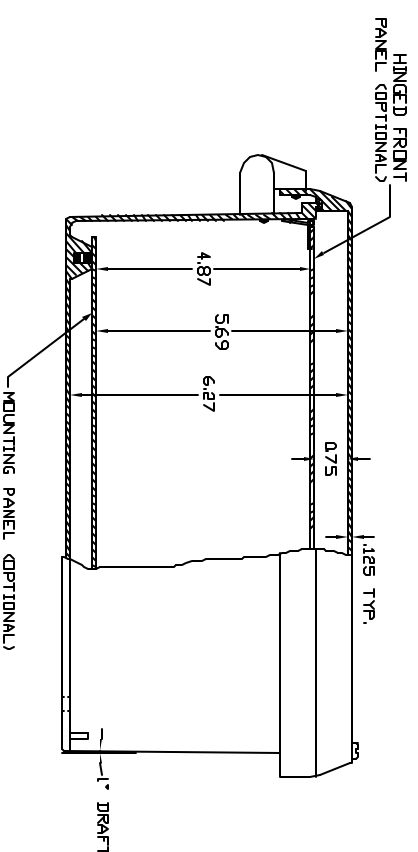

- NOTES:
1. ENCLOSURE MATERIAL MADE OF GRAY (RAL 7036)
 2. HOT MOLDED FIBERGLASS REINFORCED POLYESTER.
 3. UL LISTED PER STD. 508. (FILE# ES4-315)
 4. CSA CERTIFIED PER STD. C22.2 NO. 94. (FILE# LR36508)
 5. NEMA RATED TYPE 3, 3R, 3S, 4, 4X, 12 AND 13.
 6. IEC 529 RATED IP 68.
 7. RESISTANT TO TEMPERATURES UP TO 150 DEG C.
 8. SELF EXTINGUISHING AND HALOGEN FREE.
 9. ACCESSORIES INCLUDING: BACK PANELS, HINGEABLE FRONT PLATES, HINGED COVERS, PRINT POCKET, LATCHES, WINDOWS, AND VENTILATORS.
 9. CABINETS ARE MAINTENANCE FREE AND CORROSION RESISTANT.

UNLESS OTHERWISE SPECIFIED DIMENSIONS ARE IN INCHES DECIMALS .005 .0005 ± .005 FRACTIONS 1/16 ± .010 DO NOT SCALE DRAWINGS		WNCICKER ENCLOSURE SYSTEMS LTD. VJ SERIES ENCLOSURE WNCICKER PART# WJ1412NHV	
DRAWN KEITH CHAPMAN	DATE 2/11/01	SIZE F30X N1	DWG NO. VJ1412NHV
CHECKED DESIGN	SCALE FULL	SHEET 1 OF 1	REV 0

THE DRAWING IS THE PROPERTY OF WNCICKER ENCLOSURE SYSTEMS LTD. IT IS TO BE USED ONLY FOR THE PROJECT AND SHALL NOT BE REPRODUCED OR COPIED IN ANY MANNER WITHOUT WRITTEN PERMISSION FROM WNCICKER ENCLOSURE SYSTEMS LTD.