

REVISIONS				
ZONE	REV	DESCRIPTION	DATE	APPROVED

FRONT VIEW

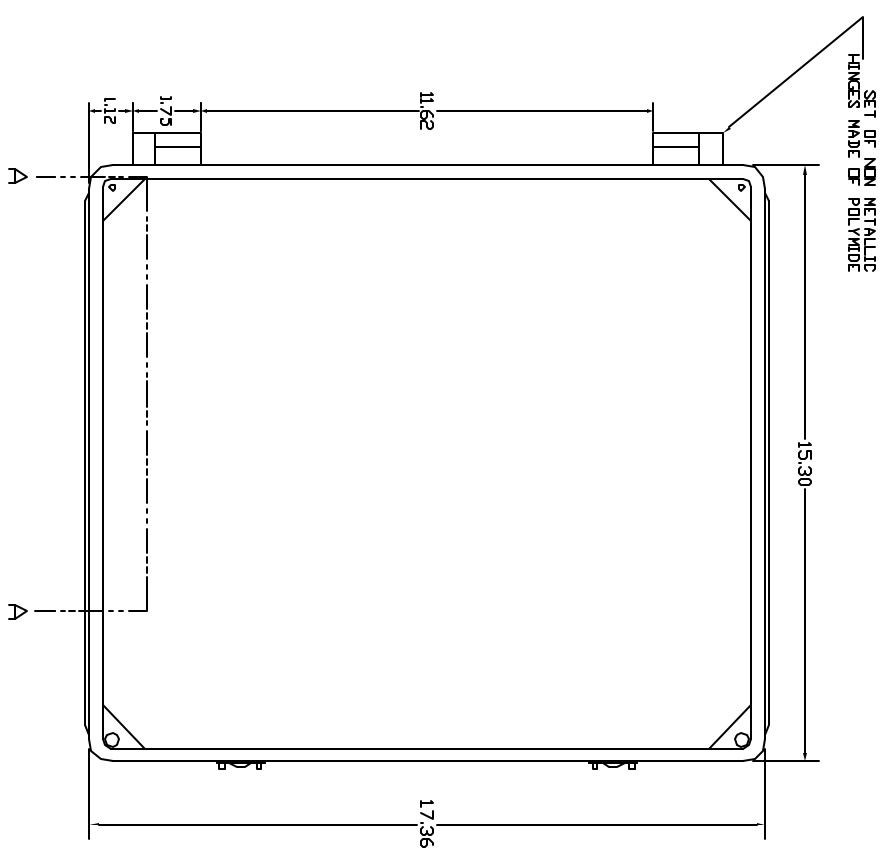

RIGHT SIDE VIEW

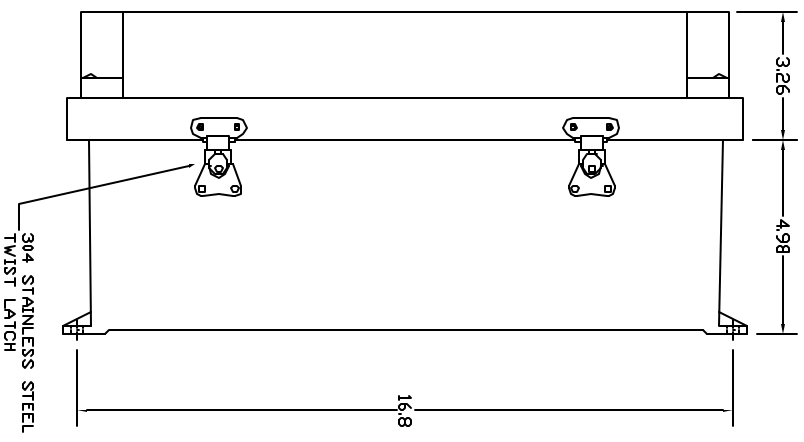

FRONT VIEW COVER REMOVED

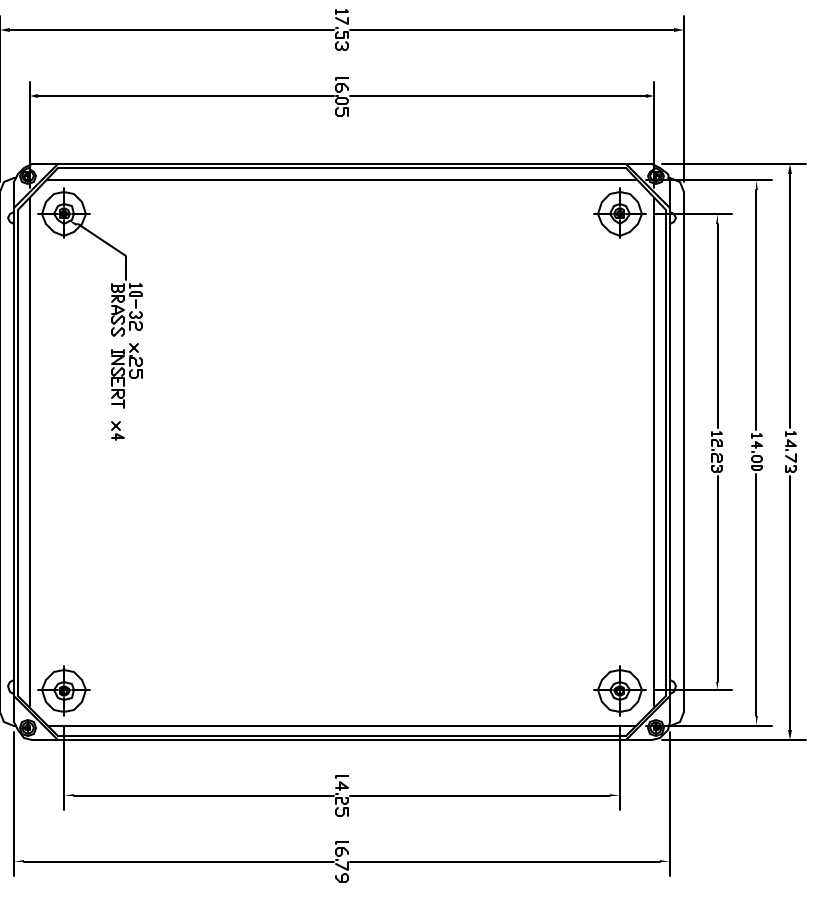

END VIEW

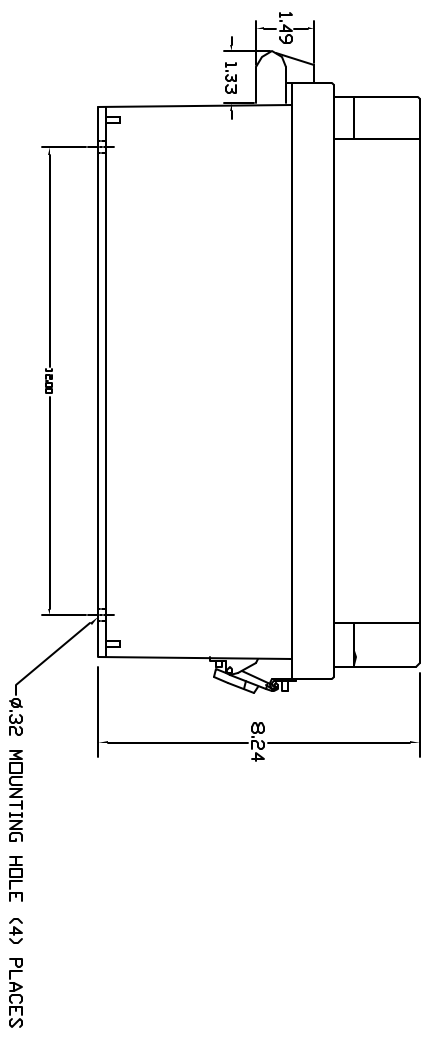

SECTION A-A

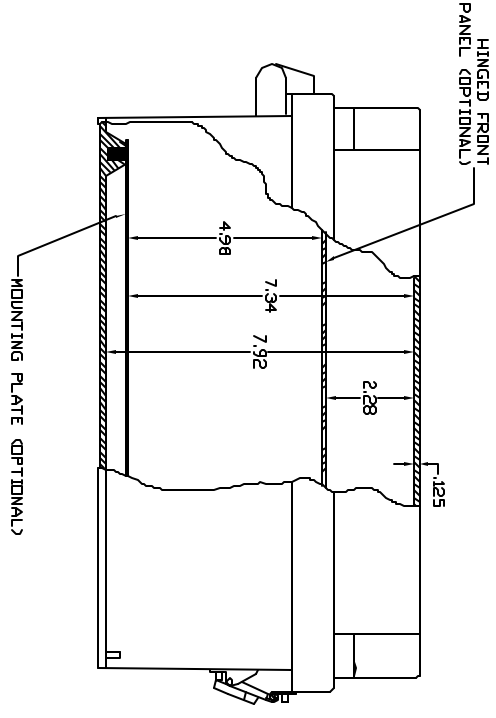

- NOTES:
- ENCLOSURE MATERIAL MADE OF GRAY (RAL 7036) HOT MOLDED FIBERGLASS REINFORCED POLYESTER.
 - UL LISTED PER STD. 508, (FILE# ES4315)
 - CSA CERTIFIED PER STD. C222 NO. 94, (FILE# LR36508)
 - NEMA RATED TYPE 3, 3R, 3S, 4, 4X, 12 AND 13.
 - IEC 329 RATED IP 68
 - TEMPERATURE RANGES FROM -50 DEG. C TO 150 DEG. C
 - SELF EXTINGUISHING AND HALOGEN FREE
 - ACCESSORIES INCLUDE BACK PANELS, DEAD FRONT PANELS, HINGED FRONT PLATES, HINGED COVERS, PRINT POCKETS, LATCHES, WINDOWS, AND VENTILATORS.
 - CABINETS ARE MAINTENANCE FREE AND CORROSION RESISTANT.

UNLESS OTHERWISE SPECIFIED
DIMENSIONS ARE IN MILLIMETERS

WYNNKIER ENCLOSURE SYSTEMS LTD.

VJ SERIES ENCLOSURE
WYNNKIER PART # RVJ1614NH-WLL2

DESIGNER	CHECKED	DATE	REV
		02/21/09	0

SCALE	SIZE	FORM NO.	DWG NO.
	D		RVJ1614NH-WLL2

THE DRAWING IS THE PROPERTY OF WYNNKIER ENCLOSURE SYSTEMS LTD. AND SHALL NOT BE REPRODUCED OR TRANSMITTED IN ANY FORM OR BY ANY MEANS, ELECTRONIC OR MECHANICAL, INCLUDING PHOTOCOPYING, RECORDING, OR BY ANY INFORMATION STORAGE AND RETRIEVAL SYSTEM.