

REVISIONS				
ZONE	REV	DESCRIPTION	DATE	APPROVED

FRONT VIEW

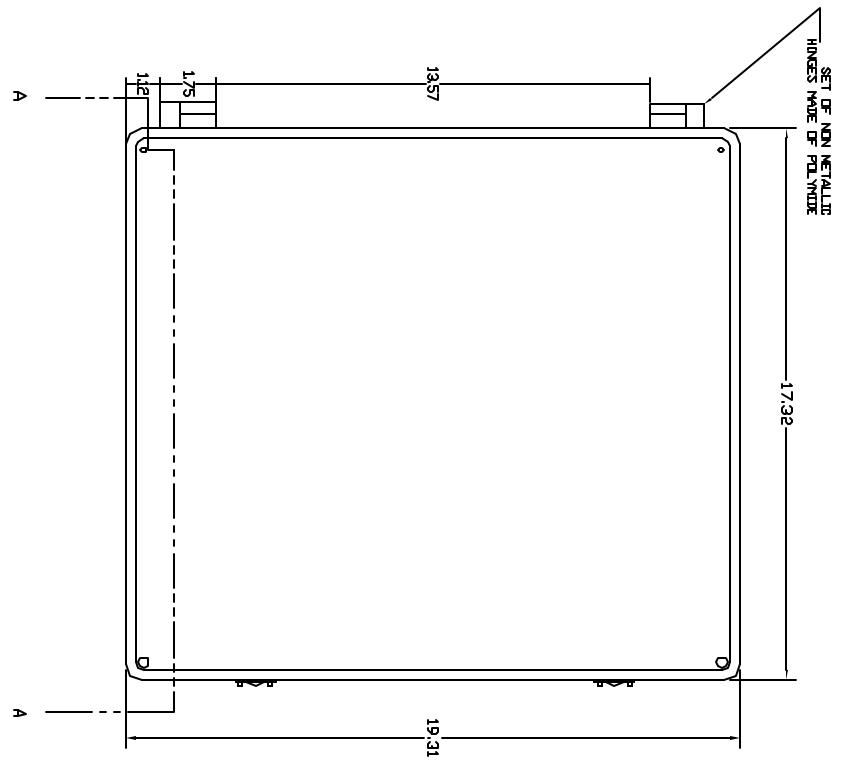

RIGHT SIDE VIEW

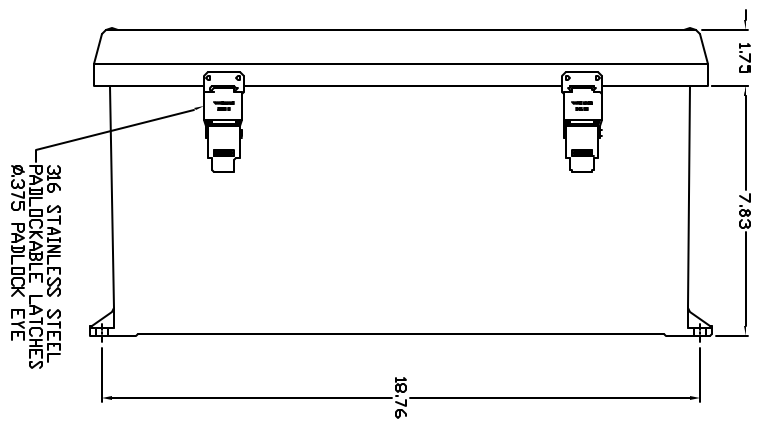

FRONT VIEW-COVER REMOVED

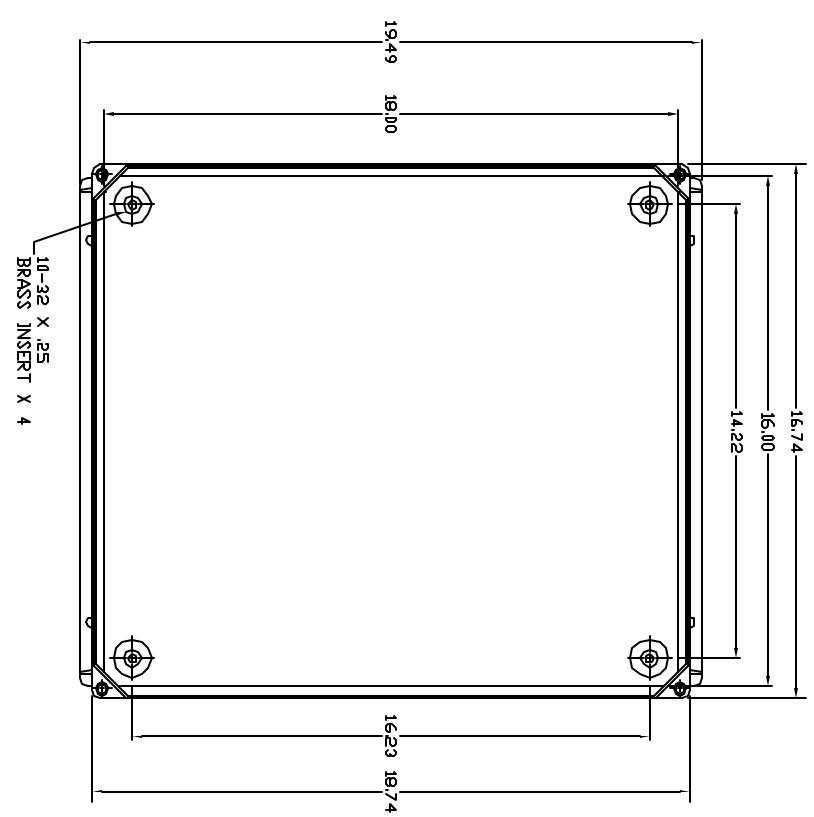

END VIEW

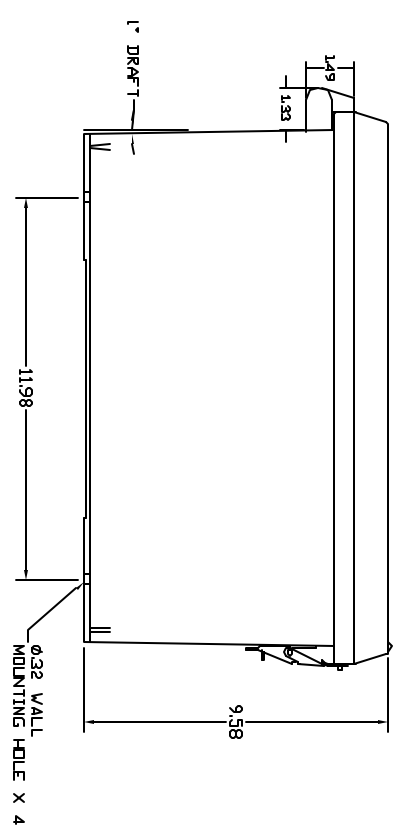

SECTION A-A

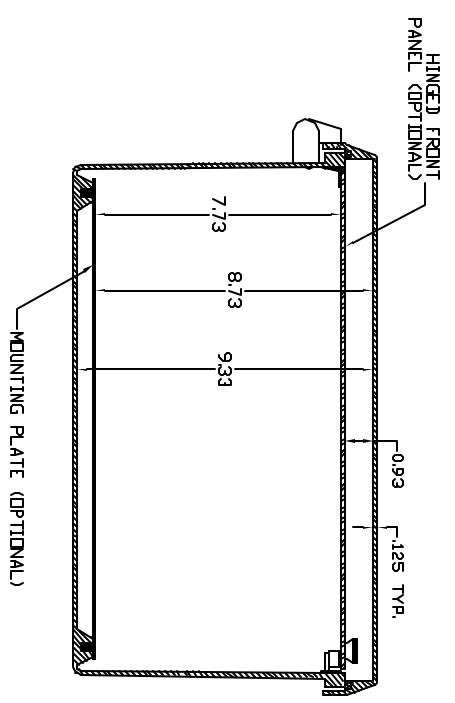

- NOTES:**
1. ENCLOSURE MATERIAL MADE OF GRAY (RAL 7036)
 2. HOT MOLDED FIBERGLASS REINFORCED POLYESTER.
 3. UL LISTED PER STD. 508. (FILE# E54315)
 4. CSA CERTIFIED PER STD. C22.2 NO. 94. (FILE# LR36508)
 5. NEMA RATED TYPE 3, 3R, 3S, 4, 4X, 12 AND 13.
 6. IEC 529 RATED IP 68.
 7. TEMPERATURE RANGES FROM -50 DEG C TO 150 DEG C.
 8. ACCESSORIES INCLUDING: BACK PANELS, DEAD FRONT PANELS, HINGED FRONT PLATES, HINGED COVERS, PRINT POCKETS, LATCHES, WINDOWS, AND VENTILATORS.
 9. CABINETS ARE MAINTENANCE FREE AND CORROSION RESISTANT.

<p>UNLESS OTHERWISE SPECIFIED: DIMENSIONS ARE IN INCHES DIMENSIONS IN PARENTHESES ARE IN MILLIMETERS</p>		<p>DATE: 2/17/01</p>	
<p>DESIGNED BY: KEITH CHAPMAN</p>	<p>CHECKED BY: KEITH CHAPMAN</p>	<p>DRAWN BY: KEITH CHAPMAN</p>	<p>DATE: 2/17/01</p>
<p>SCALE: FULL</p>		<p>SHEET</p>	
<p>THE ABOVE IS THE GENERAL AND PRELIMINARY DRAWING OF THE ENCLOSURE. IT IS THE RESPONSIBILITY OF THE USER TO VERIFY THE DIMENSIONS AND MATERIALS OF THE ENCLOSURE AGAINST THE SPECIFICATIONS OF THE MANUFACTURER'S CATALOG.</p>			

VYNCKIER
ENCLOSURE SYSTEMS INC.

VYNCKIER PART# VJ1816NHWP/L2

REV	0
DATE	2/17/01
BY	KEITH CHAPMAN
CHECKED BY	KEITH CHAPMAN
SCALE	FULL
SHEET	