

REVISIONS				
ZONE	REV	DESCRIPTION	DATE	APPROVED

FRONT VIEW

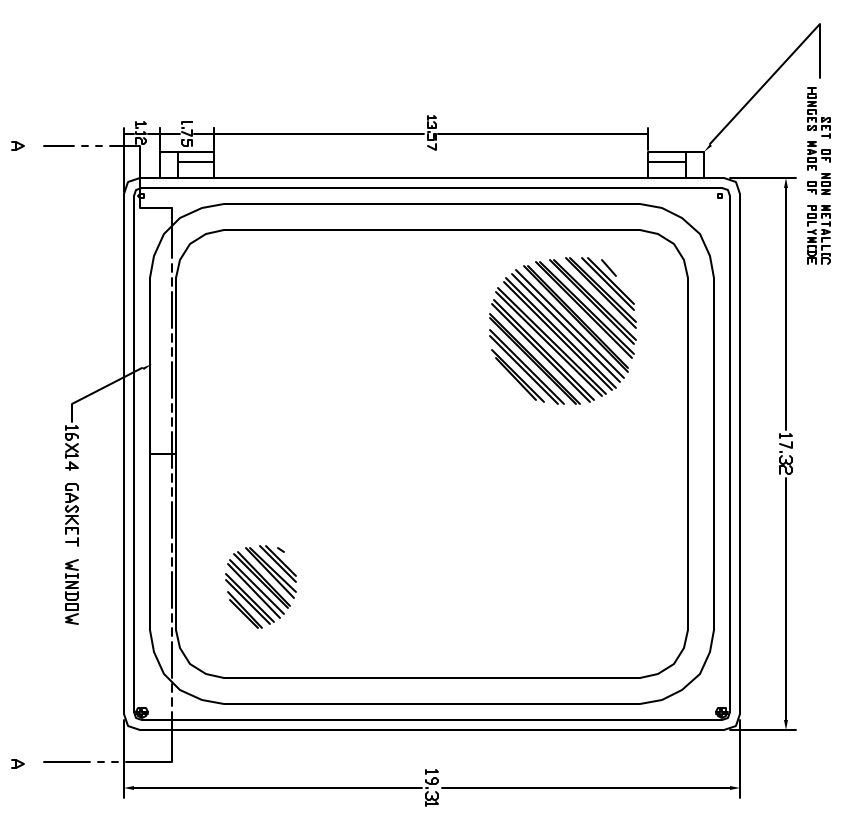

RIGHT SIDE VIEW

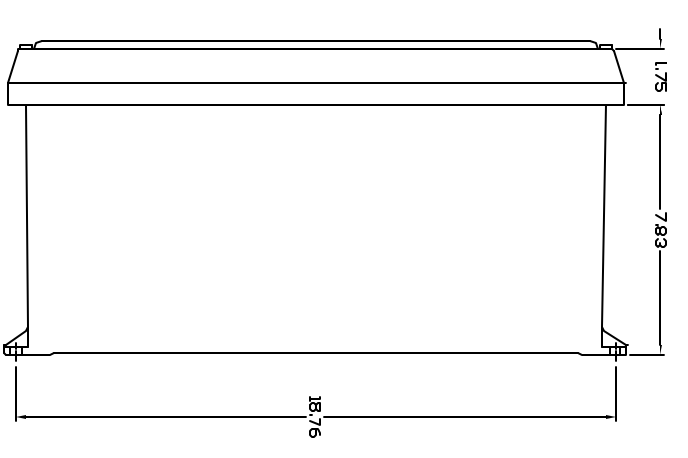

FRONT VIEW-COVER REMOVED

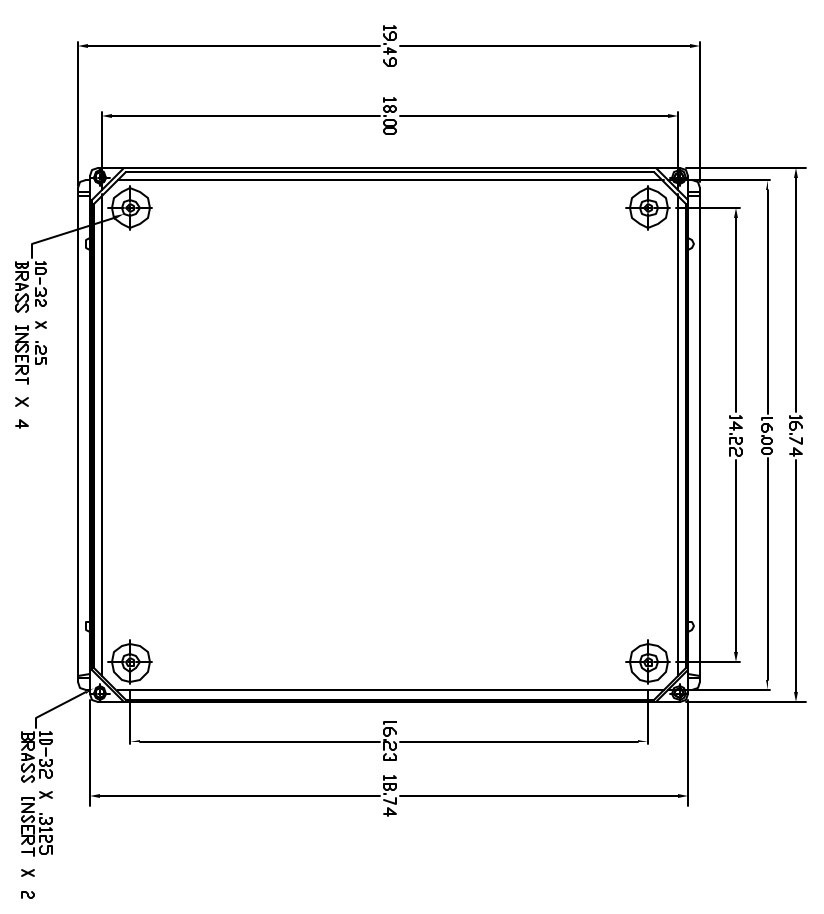

END VIEW

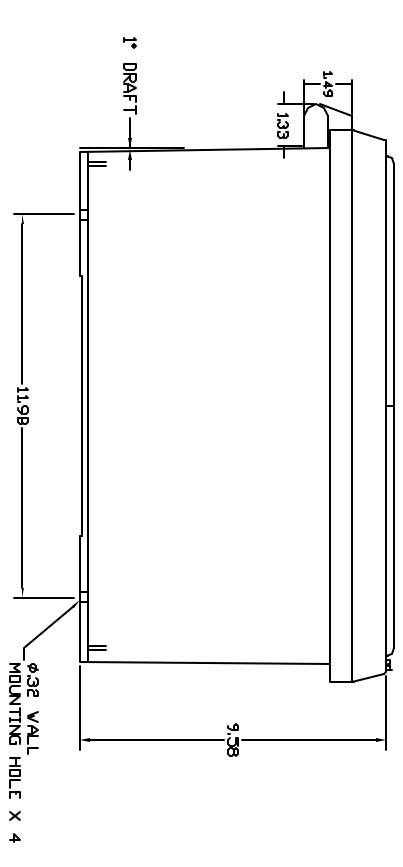

SECTION A-A

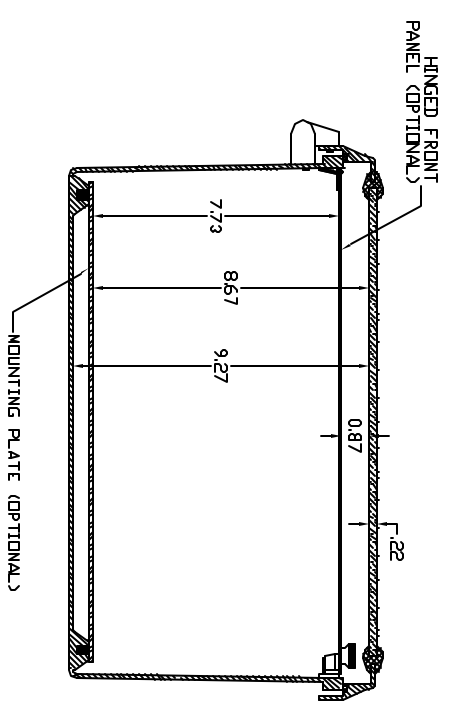

- NOTES:**
1. ENCLOSURE MATERIAL MADE OF GRAY (RAL 7036) HOT MOLDED FIBERGLASS REINFORCED POLYESTER.
 2. U.L. LISTED PER STD. 508. FILE# E54315)
 3. CSA CERTIFIED PER STD. C222 ND. 94. (FILE# LR36508)
 4. NEMA RATED TYPE 3, 3R, 3S, 4, 4X, 12 AND 13.
 5. IEC 529 RATED IP 68.
 6. TEMPERATURE RANGES FROM -50 DEG C. TO 150 DEG C.
 7. SELF EXTINGUISHING AND HALOGEN FREE.
 8. ACCESSORIES INCLUDE: BACK PANELS, DEAD FRONT PANELS, HINGED FRONT PLATES, HINGED COVERS, PRINT POCKETS, LATCHES, WINDOWS, AND VENTILATORS.
 9. CABINETS ARE MAINTENANCE FREE AND CORROSION RESISTANT.

UNLESS OTHERWISE SPECIFIED: DIMENSIONS ARE IN INCHES DECIMAL TOLERANCES .XX ± .012 .XXX ± .005 .XXX ± .020 DO NOT SCALE DRAWING		DRAWN KEITH CHAPMAN		DATE 2/7/01	
VYNCKIER ENCLOSURE SYSTEMS INC.		VYNCKIER PART# VJG1816NHW		REV 0	
CHECKED DESIGN		SIZE D		DWG NO. VJG1816NHW	
		SCALE FULL		SHEET	

THE DRAWING IS THE PROPERTY OF VYNCKIER ENCLOSURE SYSTEMS INC. IT IS TO BE USED ONLY FOR THE PROJECT AND FOR THE QUANTITY SPECIFIED THEREIN. IT IS NOT TO BE REPRODUCED OR COPIED IN ANY MANNER WITHOUT PERMISSION FROM VYNCKIER ENCLOSURE SYSTEMS INC.