

FRONT VIEW

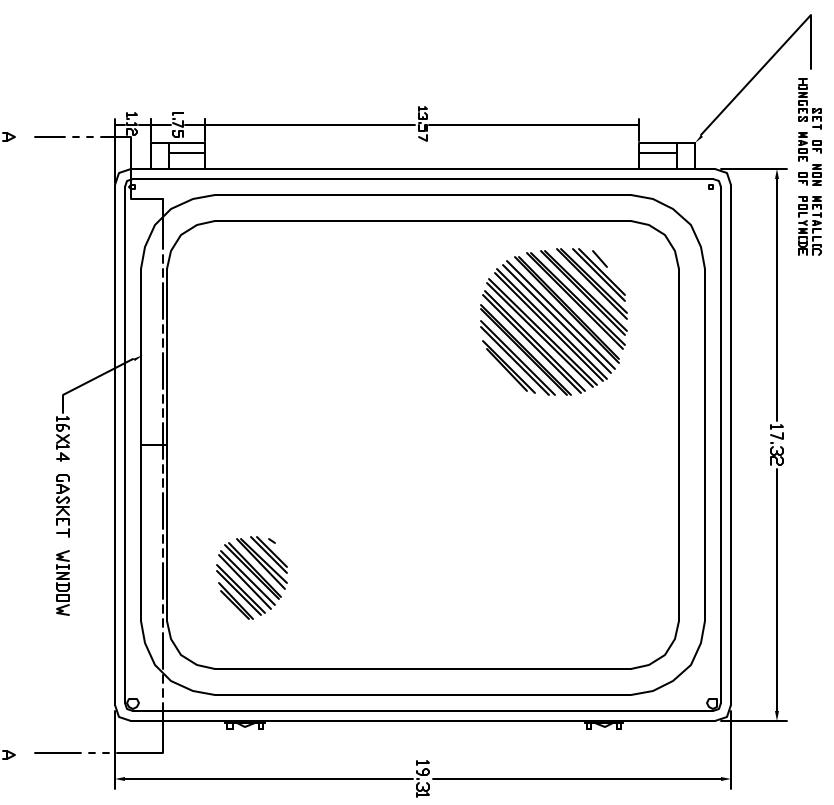

RIGHT SIDE VIEW

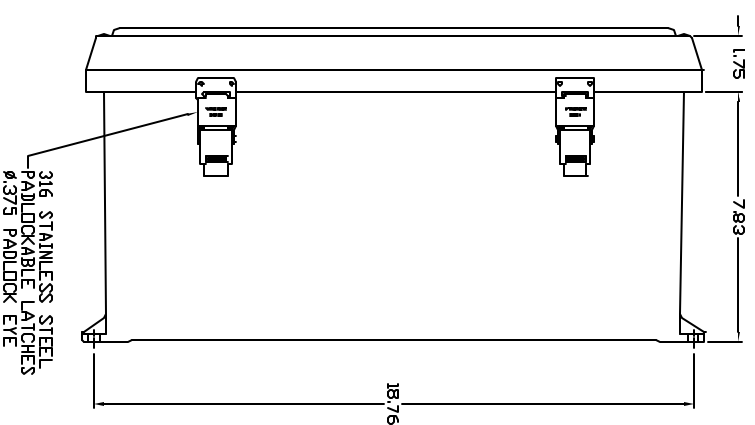

FRONT VIEW-COVER REMOVED

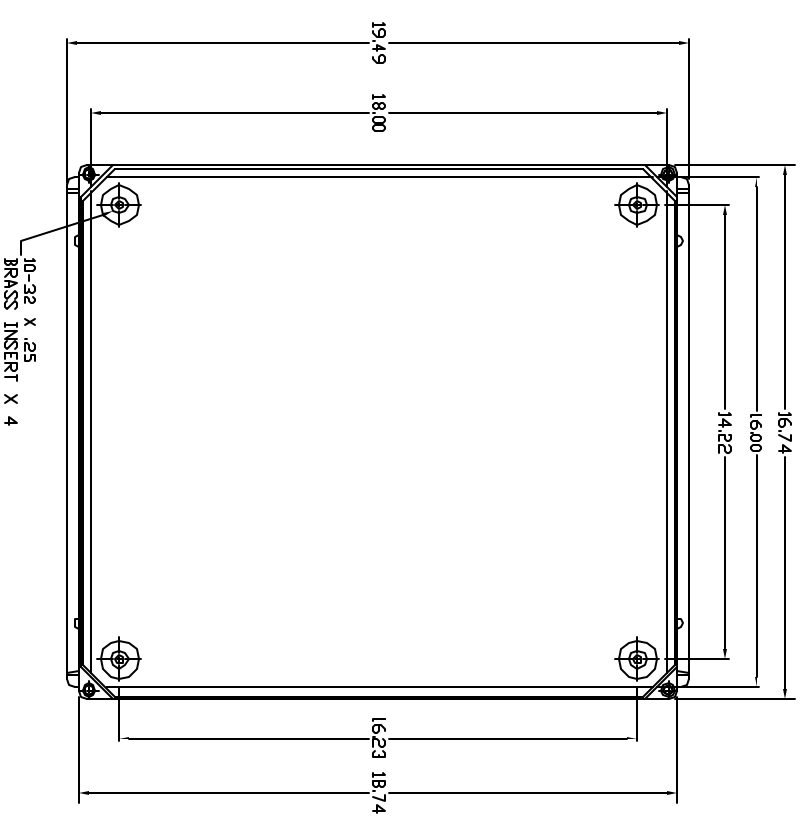

END VIEW

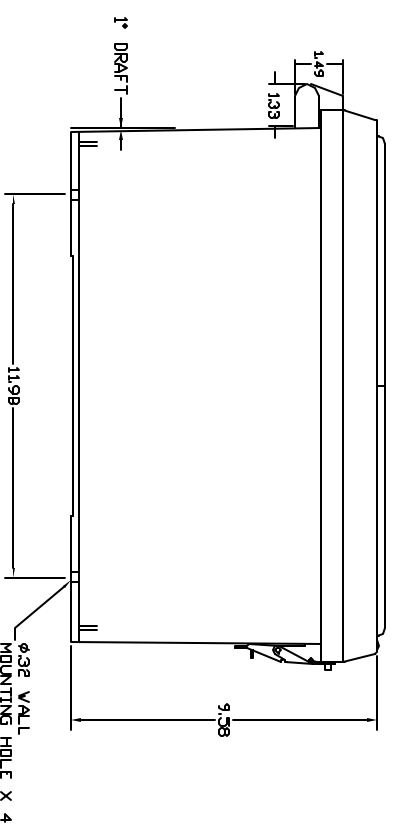

SECTION A-A

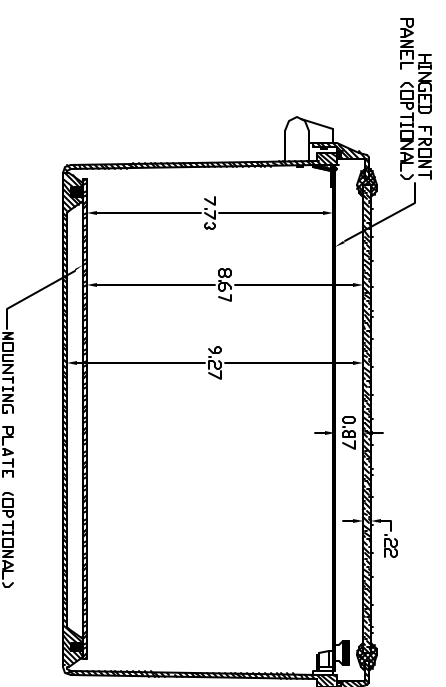

- NOTES:
1. ENCLOSURE MATERIAL MADE OF GRAY (RAL 7036) HOT MOLDED FIBERGLASS REINFORCED POLYESTER.
 2. U.L. LISTED PER STD. 508. FILE# E54315)
 3. CSA CERTIFIED PER STD. C222 ND. 94. (FILE# LR36508)
 4. NEMA RATED TYPE 3, 3R, 3S, 4, 4X, 12 AND 13.
 5. IEC 529 RATED IP 68.
 6. TEMPERATURE RANGES FROM -50 DEG C. TO 150 DEG C.
 7. SELF EXTINGUISHING AND HALOGEN FREE.
 8. ACCESSORIES INCLUDE: BACK PANELS, DEAD FRONT PANELS, HINGED FRONT PLATES, HINGED COVERS, PRINT POCKETS, LATCHES, WINDOWS, AND VENTILATORS.
 9. CABINETS ARE MAINTENANCE FREE AND CORROSION RESISTANT.

REVISIONS				
ZONE	REV	DESCRIPTION	DATE	APPROVED

THE DRAWING IS THE PROPERTY OF VYCKIER ENCLASURE SYSTEMS INC. IT IS TO BE USED ONLY FOR THE PROJECT AND SITE SPECIFICALLY IDENTIFIED HEREON. IT IS NOT TO BE REPRODUCED OR TRANSMITTED IN ANY FORM OR BY ANY MEANS, ELECTRONIC OR MECHANICAL, INCLUDING PHOTOCOPYING, RECORDING, OR BY ANY INFORMATION STORAGE AND RETRIEVAL SYSTEM, WITHOUT PERMISSION FROM VYCKIER ENCLASURE SYSTEMS INC.

UNLESS OTHERWISE SPECIFIED: DIMENSIONS ARE IN INCHES		VYCKIER ENCLASURE SYSTEMS INC.	
TOLERANCES		VYCKIER PART # VJG1816NHWP/L2	
.XX ± .012	.XXX ± .005	DATE	2/7/01
.XX ± .001	.XXX ± .001	DRAWN	KETH CHAPMAN
ØØ NOT SCALE DRAWING		CHECKED	D
		SCALE	FULL
		SHEET	